

SIMRAD

A2004 Autopilot



www.navico.com/commercial

A2004 Autopilot

The A2004 autopilot system is designed to meet the needs of professional mariners aboard Workboats, Commercial Fishing Vessels, and Passenger Vessels.

It features a proven Simrad interface, presented on a wide-angle and zero-fog colour display. Engineered for responsiveness and ease of use, the A2004 pairs a precision rotary control dial with dedicated buttons for instant access to steering modes, a custom-configurable Work mode, and automated turn patterns.

The Simrad A2004 replaces the renowned AP35 and AP60, and is perfect for vessels that don't require SOLAS Heading Control Systems (where a Simrad AP70 or AP80 would be more suitable).



FEATURES

- Proven Simrad interface designed for commercial marine applications
- Large, heavy-duty rotary control dial for precision steering
- Utilising Simrad Continuum Steering Technology - giving you the benefit of our 60 years of experience
- Optically bonded 4.1-inch colour display with 170-degree viewing angle
- Thruster integration & heavy-duty rudder feedback support
- Configurable work mode and low/high speed modes
- Automated turn patterns for fuel-efficient, hands-free manoeuvres
- No Drift steering holds course against wind and tide
- Flush or bracket mounting options
- Certified NMEA 2000® connectivity



Dedicated Professional User Interface: Builds upon the proven user interface of the Simrad AP70 and AP80 professional autopilot controllers, and delivers consistency with the latest generation of Simrad products.



Work mode: Allows the autopilot system to be configured for optimal response in a specific situation, such as a fully laden vessel.

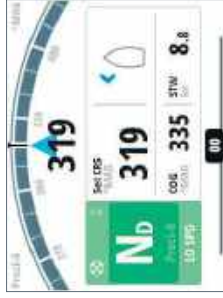

No Drift Steering: shows a visual representation of a thruster engaging.

SYSTEM CONFIGURATION

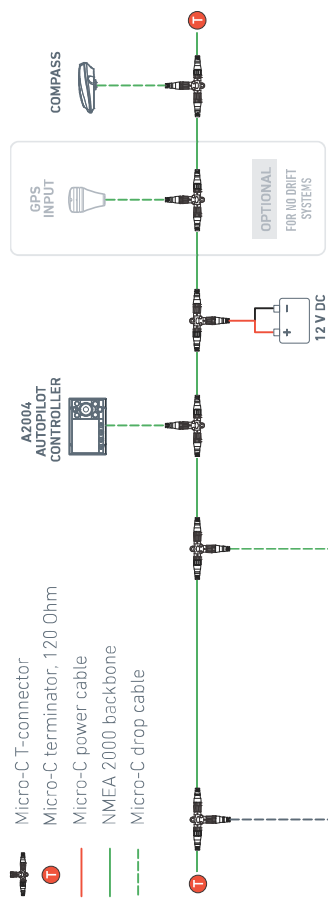

Enhance your heading control system with a choice of full function remote controls:



The A2004 also integrates with the R3000X, S35, S9, and JS10.

DIMENSIONS

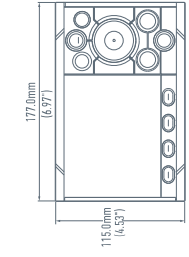

Without bracket

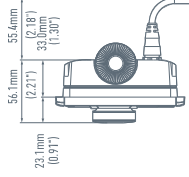

With bracket

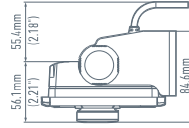
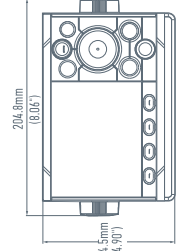

SPECIFICATIONS

A2004 Autopilot Controller

Power	
Network Load	244 mA max (Single Connection, powered by Network)
Power Consumption (@13.5 V)	Key backlight off = 1.62W (0.12 A) Key backlight max = 2.97W (0.22 A)
Environment	
Temperature	Operating: -25° to +65°C (-13°F to +149 °F) Storage: -40° to +85°C (-40°F to +185 °F)
Waterproof rating	IPx7
Mechanical	
Dimensions	177mm (Width) x 115mm (Height) x 56mm (Depth)
Weight	.51kg (1.13 lb), without mounting bracket and suncover.
Material	Plastic front & Rear, anodized aluminum rotary controller
Colour	Black
Key Material	Silicone Rubber
Compass Safe Distance	0.4m
Display	
Size	4.1" (diagonal), 4:3 Aspect ratio
Type	Transmissive TFT-LCD. White LED backlight
Bonded	Yes, Fog Free, 170° viewing angle
Resolution	320 x 240 pixels
Illumination	White for day mode. Red, green, blue, white or yellow for night mode
Networking	
NMEA2000/CAN Bus	Yes
USB	Yes, on rear for software updates, settings export and screen shots
Interfaces	
Number of drives	One Rudder with AC70, one thruster with AD80/SD80
Approvals	
Approval List	CE, RCM, NMEA2000

AC70 (Main Computer)

Power	
Local Supply	12/24 V DC, +30 - 10% Need 12 V CAN supply
Consumption local supply	100/65 mA at 12/24 V DC + load of connected equipment (motor, solenoids, clutch etc.)
NMEA 2000 Load Equivalent number (50 mA)	1
Environment	
Temperature, operation	-15°C to +55°C (5°F to 131°F)
Temperature, storage	-30°C to +70°C (-22°F to 158°F)
Protection	IPx2
Mechanical	
Weight	1 kg (2.2 lbs)
Size (length x width x height)	211x60x180mm, 8.29x2.36x7.08
Mounting	Bulkhead
Compass safe distance	1 m
Material	Plastic front and anodized aluminum back
Colour	Black
Cable inlet	Slots: 9 x 95 mm and 18 x 45 mm (0.4" x 3.7" and 0.7" x 1.8")
Networking	
NMEA 0183, IEC 61162-1, IEC 61162-2, input	1 ch
NMEA 0183, IEC 61162-1, IEC 61162-2, output	1 ch
NMEA 0183, IEC 61162-1, IEC 61162-2, Baud Rate	4.8 & 38.4 kBaud
CAN BUS/NMEA 2000	Yes
Interface	
Reversible motor control of rudder/thruster	Max continuous load 30 A, peak 50 A for 1 sec
On/off solenoid control of rudder/thruster	12/24 V DC, common lo, load range 10 mA to 10 A. (Off state=1 mA)
"Engage" output for bypass/clutch	12/24 V DC, min 10 mA, max 3 A
Rudder angle, frequency input	15 V (out), 1.4 to 5 kHz, resol. 20Hz/°, center 3.4KHz
NFU port/stbd input and mode indicator output	External open/close contact, common ret, contact current max 30 mA
Mode input	External open/close or pulse contact for SYSTEM SELECT, common ret, close to activate, contact current max 30 mA
External alarm output for buzzer/relay	Max 100 mA, voltage level as local supply
EVC (Electronic Vessel Control) interface	CAN via SG05 Gateway
Accessories	
Rudder Angle	RF25, RF300, RF45X, RF70N
Remote Controllers	FU80, NF80, QS80, R3000X, S35, S9, JS10

GLOBAL SERVICE / 7-YEAR WARRANTY



When you choose a product from the Simrad Commercial product portfolio, you are automatically protected by our global Service and Support program. Our Service & Support program aims to provide the best possible experience, even on occasions when support or replacement is required.

Comes with:

- 2 Year Warranty
- Extended Warranty Options
- 7 Year Upgrade Options
- Global Service Network

+ Certified Vessels include:

- 2 Year OnBoard Support
- 24 Hour Replacement

DISTRIBUTED BY

Navico Asia Pacific Tel: +64 9 925 4500

Navico Americas Tel: +1 832 377 9578

Navico EMEA Tel: +44 1794 510 010

Email: sales.apacnz@navico.com

Email: sales.americas@navico.com

Email: sales.emea@navico.com

SIMRAD